

Turbojet and Turbofan Engine Performance Increases Through Turbine Burners

F. Liu* and W. A. Sirignano[†]

University of California, Irvine, California 92697-3975

In a conventional turbojet and turbofan engine, fuel is burned in the main combustor before the heated high-pressure gas expands through the turbine. A turbine-burner concept was proposed in a previous paper in which combustion is continued inside the turbine to increase the efficiency and specific thrust of the turbojet engine. This concept is extended to include not only continuous burning in the turbine but also “discrete” interstage turbine burners as an intermediate option. A thermodynamic cycle analysis is performed to compare the relative performances of the conventional engine and the turbine-burner engine with different combustion options for both turbojet and turbofan configurations. Turbine-burner engines are shown to provide significantly higher specific thrust with no or only small increases in thrust specific fuel consumption compared to conventional engines. Turbine-burner engines also widen the operational range of flight Mach number and compressor pressure ratio. The performance gain of turbine-burner engines over conventional engines increases with compressor pressure ratio, fan bypass ratio, and flight Mach number.

I. Introduction

AS turbine engine designers are attempting to increase thrust-to-weight ratio and to widen the thrust range of engine operation, especially for military engines. One major consequence is that the combustor residence time can become shorter than the time required to complete combustion. Therefore, combustion would occur in the turbine passages, which in general has been considered to be undesirable. A thermodynamic analysis for the turbojet engine by the authors^{1,2} showed, however, that significant benefit can result from augmented burning in the turbine. In summary, it was shown that augmented combustion in the turbine allows for 1) a reduction in afterburner length and weight, 2) reduction in specific fuel consumption compared to the use of an afterburner, and 3) increase in specific thrust. The increase in specific thrust implies that larger thrust can be achieved with the same cross section or that the same thrust can be achieved with smaller cross section (and therefore smaller weight). For ground-based engines it was shown that combustion in the turbine coupled with heat regeneration dramatically increases both specific power and thermal efficiency. It was concluded in Refs. 1 and 2 that mixing and exothermic chemical reaction in the turbine passages offer an opportunity for a major technological improvement. Instead of the initial view that it is a problem, combustion in the turbine should be seen as an opportunity to improve performance and reduce weight. Motivated by this concept, Sirignano and Kim³ studied diffusion flames in an accelerating mixing layer by using similarity solutions. This study of diffusion flames is also extended to nonsimilar shear layers more appropriate for the flow conditions in a turbine passage.⁴

Burning fuel in a turbine rotor can be regarded as too difficult for an initial design by many experts although thermodynamically it is the most desirable process because it is possible to maintain constant temperature burning in a rotor. An alternative is to construct burners between turbine stages, which conceivably can be combined with the turbine stators. In other words, we can redesign the turbine stators (nozzles) to be combustors. If many such turbine stages were constructed, we would then approach the “continuous”

turbine burner concept discussed in Refs. 1 and 2. There is a need to quantify the relative performance gains of such “discrete” turbine burners relative to the conventional engine and the continuous turbine-burner engines when only a small number of such interstage turbine burners are used. In this paper we extend our studies in Ref. 2 on the continuous turbine-burner option for turbojets to include discrete turbine burners for both turbojet and turbofan engines. Performance comparisons are presented among the conventional turbojet and turbofan engines with or without afterburners, engines with discrete interstage burners, and engines with continuous turbine burners. It will be shown that significant gains in performance are achievable with the interstage turbine-burner option for both turbojet and turbofan engines for a range of flight and design conditions. The large margin in performance gains warrants further research in this direction for future high-performance engines.

II. Continuous Turbine-Burner and Inter-Turbine-Burner Engines

Figure 1 shows the basic idealized configuration of a turbojet/turbofan engine with the corresponding T - s diagrams of the core engine and the fan bypass. Air from the far upstream (state a) comes into the inlet/diffuser and is compressed to state 02 (the 0 here denotes stagnation state) before it splits into the core engine and the fan bypass streams. The stream that goes into the core engine is further compressed by the compressor, which usually consists of a low-pressure (LP) portion and a high-pressure (HP) portion on concentric spools, to state 03 before going into the conventional main burner where heat \dot{Q}_b is added to increase the flow temperature to T_{04} . In a conventional configuration (dashed line in Fig. 1) the HP, high-temperature gas expands through the turbine, which provides enough power to drive the compressor and fan and other engine auxiliaries. To further increase the thrust level, fuel may be injected and burned in the optional afterburner to increase further the temperature of the gas before the flow expands through the nozzle to produce the high-speed jet. For a turbofan engine part of the flow that comes into the inlet is diverted to the fan bypass. The pressure of the bypass flow is increased through the fan. The flow state after the fan is marked as 03 f . An optional duct burner behind the fan can also be used to increase the thrust. The flow then expands through the bypass nozzle into the atmosphere or mixes with the flow from the core engine before expanding through a common nozzle.

Specific thrust (ST) and thrust specific fuel consumption rate (TSFC) are two fundamental performance measures for a jet engine

Presented as Paper 2000-0741 at the 38th AIAA Aerospace Sciences Meeting, Reno, NV, 10–13 January 2000; received 15 February 2000; revision received 30 August 2000; accepted for publication 13 September 2000. Copyright © 2000 by F. Liu and W. A. Sirignano. Published by the American Institute of Aeronautics and Astronautics, Inc., with permission.

*Associate Professor, Mechanical and Aerospace Engineering, Senior Member AIAA.

[†]Professor, Mechanical and Aerospace Engineering, Fellow AIAA.

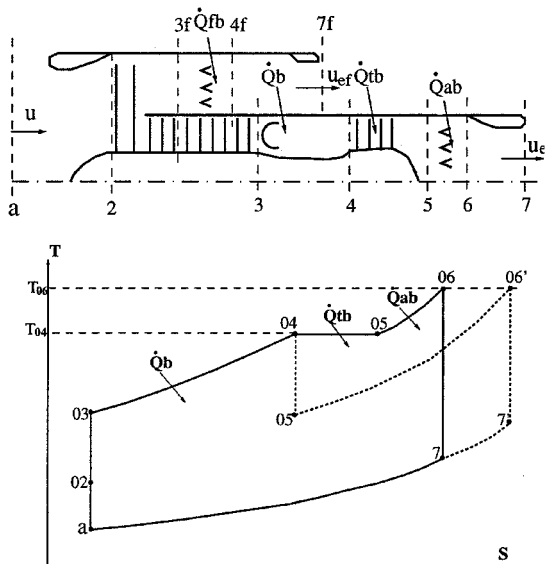

Fig. 1 Comparison of thermodynamic cycles with and without the turbine burner.

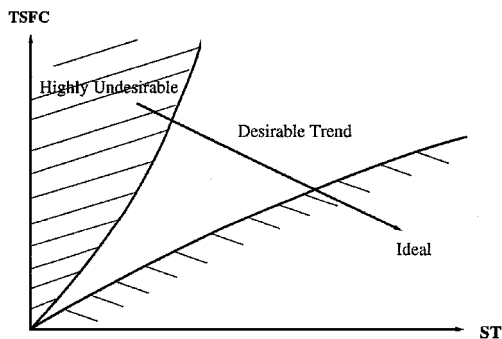

Fig. 2 Desired ST and TSFC range.

designed to produce thrust. Specific thrust is defined as the thrust per unit mass flux of air

$$ST = T / \dot{m}_a \tag{1}$$

For a turbojet engine \dot{m}_a is the air mass-flow rate of the whole engine. For a turbofan engine the definition of \dot{m}_a used in this paper is the air mass-flow rate of the core engine. The total air mass-flow rate of the engine is then $(1 + \beta)\dot{m}_a$, where β is the bypass ratio of the fan. A higher ST means a higher thrust level for the same engine cross section and thus smaller engine size and lighter weight. Thrust specific fuel consumption rate is defined as the fuel flow rate per unit thrust:

$$TSFC = \dot{m}_f / T \tag{2}$$

where \dot{m}_f is the total fuel mass-flow rate for the complete engine. A lower TSFC means less fuel consumption for the same thrust level. Unfortunately, the two performance parameters trade off with each other. It is difficult to design an engine that has both low TSFC and high ST. On a TSFC-ST map, as shown in Fig. 2, it is desirable to move the design point of an engine toward the right-hand side. In the discussion to follow where we study the performances of the various engines, we will plot the TSFC-ST loci of the engines as we vary a design parameter, such as the compressor pressure ratio or the flight Mach number to show that the proposed turbine-burner engines indeed move in the desired direction compared to the conventional engines.

The TSFC is determined by the thermal and propulsion efficiencies η_t and η_p , respectively. The thermal efficiency is defined as

$$\eta_t = \frac{(KE)_{gain}}{\dot{m}_f Q_R} = \frac{KE \text{ of exhaust gas} - KE \text{ of inlet air}}{Q_R \dot{m}_f} \tag{3}$$

where KE stands for kinetic energy and Q_R is the heat content of the fuel. The propulsion efficiency is defined as

$$\eta_p = Tu / (KE)_{gain} \tag{4}$$

where u is the flight velocity. Therefore, the thermal efficiency indicates how efficient the engine is converting the heat to kinetic energy as a gas generator. The propulsion efficiency tells us how efficient the engine is using the kinetic energy generated by the gas generator for propulsion purposes. An overall efficiency η_0 is then defined as

$$\eta_0 = \eta_t \eta_p \tag{5}$$

For a given flight speed and fuel type it is clear from Eqs. (2-4) that

$$TSFC \sim 1/\eta_0 = (1/\eta_t)(1/\eta_p) \tag{6}$$

Any increase in thermal efficiency or propulsion efficiency will bring down the fuel consumption rate. The turbofan engine significantly increases the propulsion efficiency over its turbojet counterpart as a result of increased mass of the airflow. For the same momentum gain the kinetic energy carried away by the exhaust air (including the bypass flow) is less in the turbofan engine case than in the turbojet case. In the following sections we will plot and compare the thermal, propulsion, and overall efficiencies of the different engine configurations. Examination of these parameters helps us understand the strengths and weaknesses of the different engine types.

In the conventional turbojet configuration the basic ideal thermodynamic cycle is the Brayton cycle, for which the thermal efficiency is known to be

$$\eta_t = 1 - (1/\pi_c)^{(\gamma-1)/\gamma} \left(1 / \left\{ 1 + [(\gamma-1)/2] M_\infty^2 \right\} \right) \tag{7}$$

where π_c is the compressor pressure ratio and M_∞ is the flight Mach number. To increase efficiency (i.e., decrease TSFC), one has to increase the pressure ratio. However, higher pressure ratio increases the total temperature of the flow entering the combustor and therefore limits the amount of heat that can be added in the combustor because of the maximum turbine inlet temperature limit. As such, the conventional base turbojet/turbofan engine is limited in the maximum value of specific thrust. The afterburner increases the power levels of the engine, but because fuel is burned at a lower pressure compared to the main burner pressure the overall cycle efficiency is reduced. Therefore, the use of an afterburner increases the specific thrust at the expense of the fuel consumption rate. A duct burner in the fan bypass has the same effect except that it has even lower efficiencies because the pressure ratio in the fan bypass is usually lower than that in the core engine.

To remedy the efficiency decrease because of the use of afterburner, the turbine-burner was conceived^{1,2} in which one adds heat in the turbine where the pressure levels are higher than in the afterburner. The ideal turbine-burner option is to add heat to the flow while it does work to the rotor at the same time so that the stagnation temperature in the turbine stays constant. By doing this, Ref. 2 showed that the contention between ST and TSFC can be significantly relieved compared to the conventional engine. It was shown that significant gain in ST can be obtained for a turbojet engine with a small increase in fuel consumption by using the turbine-burner concept. Figure 3a shows the continuous turbine-burner cycle, which we denote as the CTB cycle.

However, it is yet practically difficult to perform combustion in the turbine rotor at the present time. An alternative for a first design is to convert the turbine stators or nozzles into also combustors and therefore effectively introduce inter-stage turbine burners (ITB) without increasing the engine length. We may have one, two, or more such ITB as shown in Figs. 3b-3d. We denote such cycles as the M -ITB cycles with M being the number of interstage burners. Obviously, as M goes to infinity the M -ITB cycle approaches the continuous turbine-burn cycle, that is the CTB cycle.

In this paper we extend our cycle analysis in Ref. 2 to calculate the preceding M -ITB cycles and also for turbofan engines. We

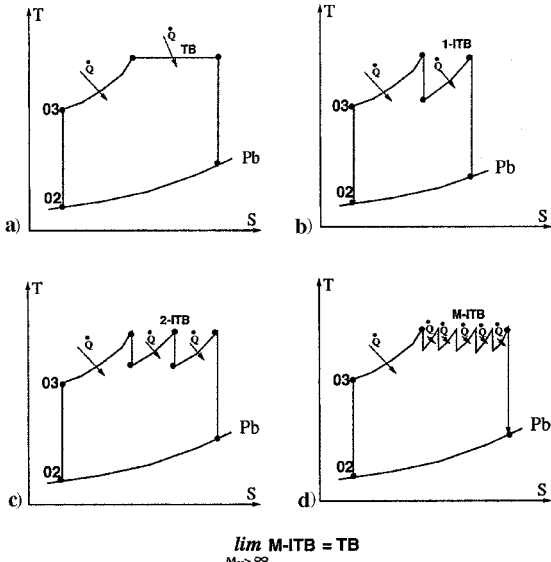

Fig. 3 TB and the M -ITB cycles.

compare engine performances at different flight Mach numbers and compressor compression ratios for a number of engine configurations, including the conventional base-engine configuration with or without an afterburner, the 1-ITB engine, the 2-ITB engine, and the CTB engine configurations. Both the turbojet and the turbofan options are considered. The basic definitions of design and performance parameters and the method of analysis used in this paper closely follow those in the book by Hill and Peterson.⁵ Details of the computational equations and the component efficiencies of the core engine used in the computation are listed in Ref. 2. For the case of turbofan engines, the fan adiabatic efficiency is taken to be 0.88. The fan nozzle efficiency is taken to be 0.97.

III. Variation of Compressor Pressure Ratios

A. Supersonic Flight

Let us first consider turbojet engines at supersonic flight, which are probably more relevant for military engines. Figure 4 shows performance comparisons among the different configurations for varying pressure ratios at flight Mach number $M_\infty = 2.0$ with maximum allowable turbine inlet temperature $T_{04} = 1500$ K and maximum afterburner temperature $T_{06} = 1900$ K. The turbine power ratios are

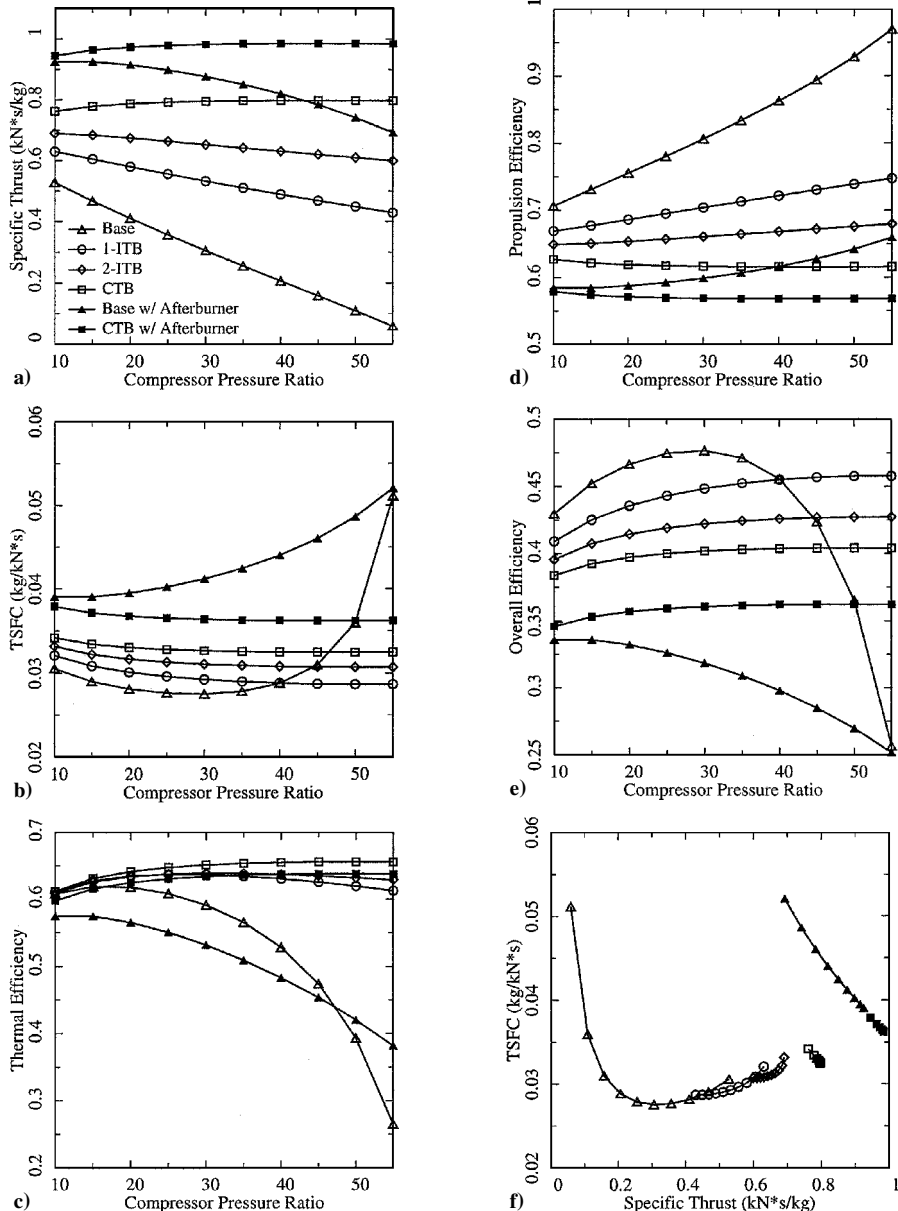

Fig. 4 Performances of turbojet engines vs compressor pressure ratio at $M_\infty = 2$, $T_{04} = 1500$ K, and $T_{06} = 1900$ K.

fixed at 40 : 60 and 33 : 33 : 34 for the 1-ITB and 2-ITB engines, respectively.

Figures 4a–4f show the comparisons of the ST, TSFC, thermal efficiency η_t , propulsion efficiency η_p , overall efficiency η_0 , and the ST-TSFC map. The specific thrust of the base conventional engine drops quickly as the compression ratio increases for the reason discussed in the preceding section that the increased compression raises the temperature of the gas entering the main combustor and therefore reduces the amount of heat that can be added. Although the TSFC decreases initially, it increases rapidly at higher pressure ratios when the total amount of heat that can be added to the system is reduced to such a low level that it is only enough to overcome the losses as a result of nonideal component efficiencies. This is also seen from the thermal efficiency plot shown in Fig. 4c. The thermal efficiency of the base engine first increases as the pressure ratio increases, but then quickly drops as the pressure ratio goes beyond 20.

The propulsion efficiency of the base engine does increase as the pressure ratio increases. However, the engine is really not producing much thrust at high compression ratios. The exhaust velocity of the jet approaches the incoming flow of the engine as the pressure ratio increases. In the limit the jet velocity becomes the same as that of the incoming flow, producing zero thrust although the propulsion efficiency becomes one. The overall efficiency of the engine still goes to zero because of the decreased thermal efficiency.

Adding an afterburner to the base engine dramatically increases the specific thrust, but it also increases the TSFC tremendously. The reason for this can be clearly seen from Figs. 4c and 4d. The afterburner reduces both the thermal and the propulsion efficiencies. Consequently, the base engine with the afterburner has the lowest overall efficiency and thus the highest fuel consumption rate. The thermal efficiency is reduced because fuel is added at a lower pressure in the afterburner. Reduction of propulsion efficiency is a concomitant to the increase of specific thrust in a given engine configuration for the increase of thrust is brought about by increasing the jet velocity. Clearly, the afterburner design is really a very poor concept to remedy the deficiency of low specific thrust for the base turbojet engine.

As shown in Ref. 2, the continuous turbine burner concept provides a much more efficient and effective way to increase the specific thrust of a conventional engine. The turbine-burner, the 1-ITB, and the 2-ITB engines all provide significantly greater ST with minimum increase in TSFC as shown in Figs. 4a–4f. The various types of turbine burners add heat at higher pressure ratios compared to the afterburner. Therefore, they have higher thermal efficiencies (Fig. 4c). In addition, the thermal efficiency of such engines increases with pressure ratio except that of the 1-ITB engine, which showed only a slight decrease at high pressure ratios. This is because, unlike the conventional base engine, the amount of heat added to the various types of turbine-burner engines is not limited by the compressor compression ratio because we are able to add heat in the turbine stages without going beyond the maximum turbine temperature. Therefore, the specific thrust of the turbine-burner engines remains high at higher pressure ratios.

The CTB version apparently provides the highest specific thrust as a result of the continuous combustion in the turbine. It also has the highest thermal efficiency. The essential advantage of a CTB engine is that it eliminates the limit on the amount of heat that can be added to the engine and thus the limit on the specific thrust of the engine without sacrificing the thermal efficiency. The CTB engine with an afterburner further increases the specific thrust but at the cost of higher specific fuel consumption as a result of the lower thermal and propulsion efficiencies of the added afterburner. Therefore, the addition of an afterburner on top of a turbine-burner type of engine is redundant and inefficient.

The CTB engine has both the highest thermal efficiency and the highest specific thrust of all nonafterburner engines at all pressure levels. Unfortunately, the higher specific thrust level of the CTB engine inevitably incurs a lower propulsion efficiency (Fig. 4d) because of the high-exhaust jet velocity needed for the higher specific thrust as mentioned in the preceding paragraph. Therefore, the overall efficiency and the specific fuel consumption is relatively higher

than the base engine. However, the specific fuel consumption rate of the CTB engine is significantly lower than the base engine with an afterburner, whereas the CTB engine provides comparable or even higher specific thrust than the base engine with the afterburner for the specified maximum afterburner temperature $T_{06} = 1900$ K. For military engines that may allow a higher T_{06} , the base engine with an afterburner may have higher thrust but then again would have much lower fuel efficiency because the extra heat would be added at the lowest pressure. This shows that the CTB engine is a far better choice than the afterburner engine for missions that require very high specific thrust.

For missions of median specific thrust levels, the 1-ITB and 2-ITB engines provide a means of controlling the total amount of heat addition and thus the specific thrust because combustion is limited to only part of the turbine stages. The thermal efficiencies of the 1-ITB and 2-ITB engines are at the same level of the CTB engine although slightly lower at HP ratios (Fig. 4c). The controlled thrust levels, however, offer us the benefit of higher propulsion efficiencies compared to the CTB and CTB with afterburner versions as can be seen in Fig. 4d. Consequently, the 1-ITB and 2-ITB engines provide better overall efficiency and thus better fuel economy as shown in Figs. 4e and 4b. Comparing Fig. 4f with Fig. 2, we see that all of these turbine-burner and inter-turbine-burner engines are moving in the desirable direction on the TSFC-ST map.

As the number of ITBs increase, the engine performance approaches that of the CTB engine. With the CTB and ITB engines the ST is almost independent of compression ratio. At high compression ratios the 2-ITB and the CTB engines provide the same ST levels of an afterburner type of engine but with much less fuel consumption rate. The 1-ITB, 2-ITB, and potentially the *M*-ITB engines fit nicely in between the base engine and the CTB engine designs because they maintain the high thermal efficiency of the CTB engine while keeping a good balance of the specific thrust and the propulsion efficiency. It is to our advantage to control the number of ITBs or the amount of fuel added in the TB to reach the best balance of TSFC and ST for a given mission requirement.

B. Subsonic Flight

Next, the same types of engines are examined for subsonic flight. Figures 5a–5f show the performance parameters at $M_\infty = 0.87$. Clearly, the relative standing of the various engine types remain the same as in the supersonic case. Therefore, the same discussions in the preceding paragraph apply. However, we do notice that, at lower flight Mach numbers, the base engine is capable of operating at higher compressor pressure ratios than in the supersonic flight case because of the lower ram pressure rise as a result of flight speed. In the $M_\infty = 2$ case the base engine ceases to produce any thrust at compressor pressure ratios beyond 55 because at that time the overall compression of the incoming flow brings the main combustion inlet temperature to a high level that no heat can be added to the engine without exceeding the 1500 K maximum turbine inlet temperature limit. The turbine-burner type of engines, however, can still operate at this or even higher compression ratios because heat can still be added in the turbine burner or inter-state turbine burners.

The most significant difference between the subsonic and supersonic cases is in the propulsion efficiencies. It is well known that turbojets lose propulsion efficiency at low flight Mach numbers. Figure 5d shows that the propulsion efficiencies of all of the engines become smaller at $M_\infty = 0.87$ than at $M_\infty = 2$. This is understandable because we know that the turbine-burner engines produce much higher thrusts than the base engine, but to produce the higher thrust level at the low flight M_∞ penalizes these engines because pure turbojets have low propulsion efficiency at low flight Mach numbers.

C. Turbofan Configuration

The turbofan configuration offers a resolution for the low propulsion efficiency of the turbojets by imparting momentum to a fan bypass flow. In this way the average exhaust velocity of the core engine and the fan becomes low for the same thrust because of the

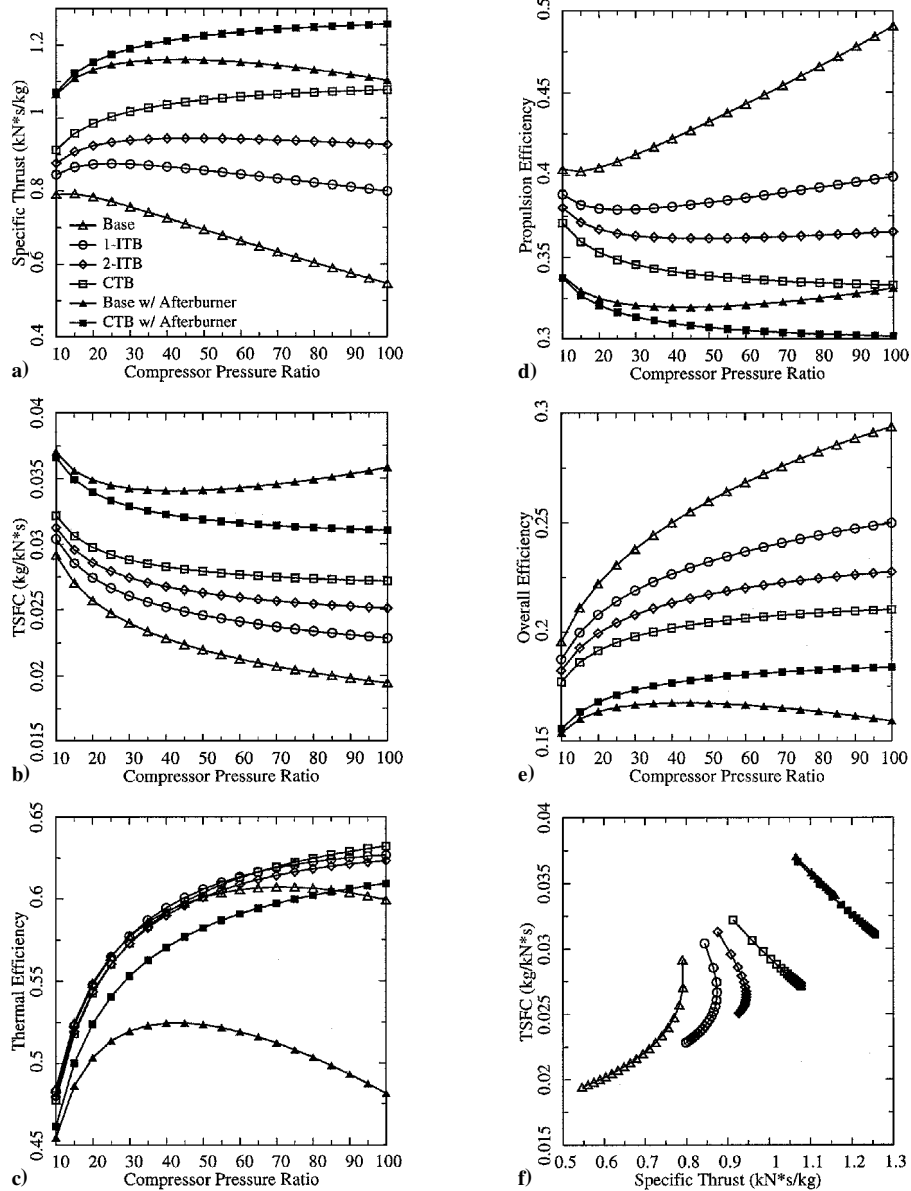

Fig. 5 Performances of turbojet engines vs compressor pressure ratio at $M_\infty = 0.87$, $T_{04} = 1500$ K, and $T_{06} = 1900$ K.

increased total amount of propulsive mass of air. The added fan bypass that increases the total airflow, however, does not significantly increase the engine weight and size (except for the added fan duct) because the core engine remains almost the same. The turbine-burner engine type as a gas generator is capable of producing much greater power than the base engine type because of its higher thermal efficiency and capacity of greater heat addition. It is best for the turbine-burner type of engines to be used in a configuration in which this high power can be utilized most efficiently to produce thrust. It is expected that the turbine burners combined with a high-bypass turbofan engine will give the best combination of both high thermal and propulsion efficiencies while at the same time high specific thrust.

Figures 6 and 7 show performance comparisons for turbofan engines with a bypass ratio of 5 and 8, respectively, at flight Mach number $M_\infty = 0.87$. The fan pressure ratio is 1.65 for both cases. The relative standings of the various engines are the same as before. However, we notice that the propulsion efficiencies of all of the engines increase compared to the turbojet counterparts. The turbine-burner types of engines benefit more from the fan bypass flow than the base engine type. This can be seen by comparing Fig. 6f to Fig. 5f. Compared to the turbojet engine case shown by Fig. 5f, the turbine-burner type of engines show a more desirable trend in the

TSFC-ST map because they move more in the high ST direction with less increase in TSFC. This trend is further enhanced when we increase the bypass ratio from 5 to 8 as shown in Fig. 7f. At a pressure ratio of 70 or higher, the 1-ITB engine is able to produce around 30% more specific thrust with almost the same fuel consumption rate of the base engine at its optimum pressure ratio in the range of 30 to 40 as can be seen in Figs. 7a and 7b. At pressure ratios beyond 40, the base engine starts to suffer from large decreases of specific thrust. At pressure ratios over 70, the core engine of the base engines with or without the afterburner starts to yield negative thrust because it cannot produce enough power to drive the fan. For this reason no points are plotted for the base engines for compressor pressure ratios over 70 in Fig. 7.

IV. Variation of Fan Bypass Ratios

We argued in the preceding section that it is best to maximize the propulsion efficiency in order to make use of the high energy gas produced at high thermal efficiency by the core gas generator. It is then useful to see the effect of bypass ratio of a turbofan engine as a design parameter in more detail. Figure 8 shows the performance parameters vs the bypass ratios at a compression ratio of 40. Although these curves now take different shapes from curves in the

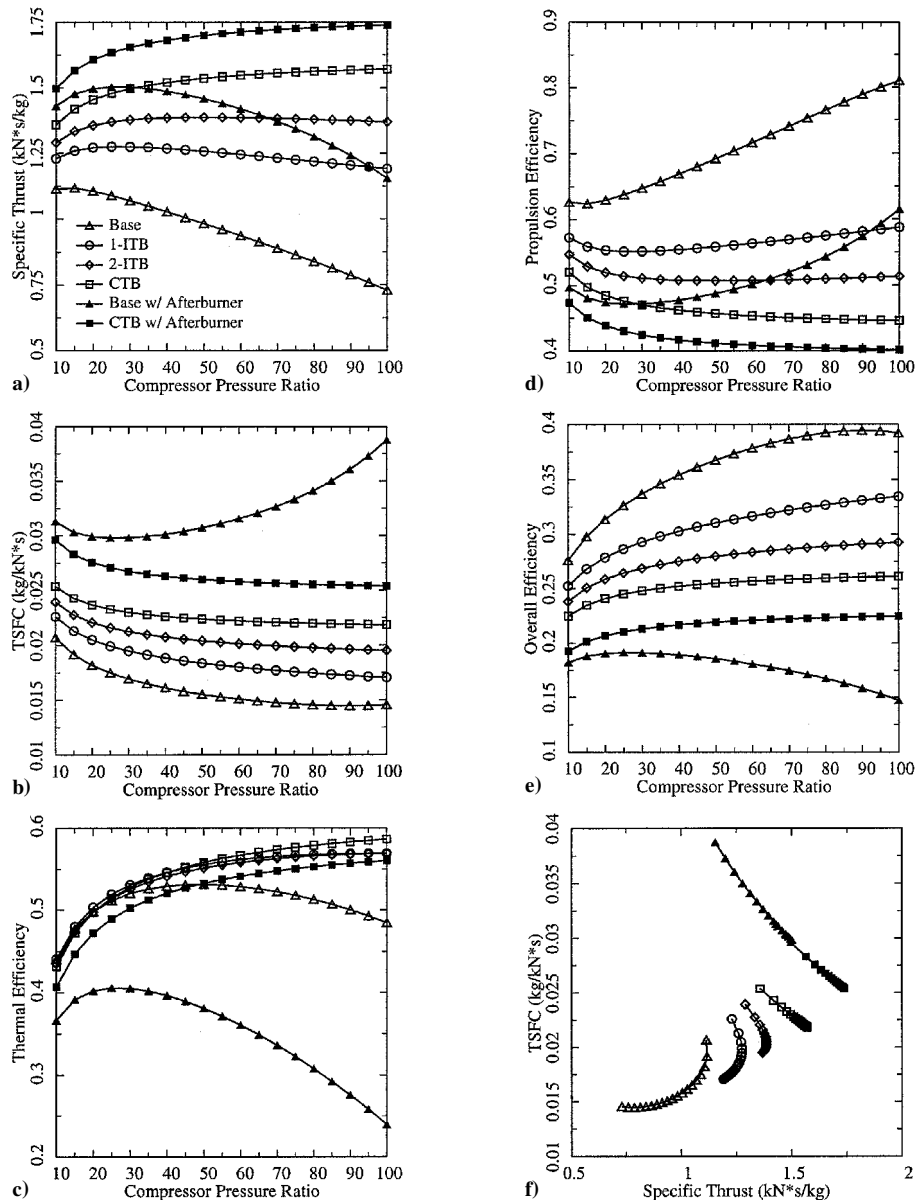

Fig. 6 Performances of turbofan engines vs compressor pressure ratio at $M_\infty = 0.87$, $T_{04} = 1500$ K, $T_{06} = 1900$ K, $\beta = 5$, and $\pi_f = 1.65$.

preceding section on the variation of pressure ratios, they still show the same relative standing of the various engines. To be noticed, however, is that the specific thrust gain by the turbine-burner engines over the base engine widens significantly as the bypass ratio increases (Fig. 8a), while the specific fuel consumption rate decreases to approach the level of the base engine (Fig. 8b). This is a clear indication that the turbine-burner engines benefit more from the increased bypass ratio than the base engine, confirming our preceding discussions. In addition, we notice that the base engines stop producing positive thrust for bypass ratios over 10. The large-bypass flow drains all of the power from the core engine in such situations. The turbine-burner type of engines is capable of operating with a much larger-bypass ratio with decreasing fuel consumption rate and no sign of decreased specific thrust. In fact, the 1-ITB engine appears to operate optimally with a bypass ratio of 13. With that bypass ratio the 1-ITB engine produces more than 50% thrust with no more than 10% increase in fuel consumption rate than the base engine with its optimal bypass ratio around eight.

V. Variation of Fan Pressure Ratios

It is clear from the preceding discussions that the fan bypass flow improves the efficiencies of the turbine-burner engines more than those for the base engines. Another way to increase the en-

ergy supply to the bypass flow is to increase the fan pressure ratio. Figure 9 shows the performance comparisons when the fan pressure ratio is varied from 1.1 to 1.9 for a bypass ratio of 8. Other parameters are the same as before. The relative standing of the engines for all of the performance parameters remain the same as before. Figures 9a and 9b show that the turbine-burner engines gain more from increased fan pressure ratio than the base engines. The specific thrusts of the turbine-burner engines increase with fan pressure ratio at faster rates than those for the base engines while the specific fuel consumption rates continue to decrease without leveling off as quickly as those for the base engines.

VI. Variation of Flight Mach Number

Figure 10 shows the performance comparisons for the various turbojet engines with flight Mach number in the range of 0 to 2.5. One can see that all of the engine types exhibit decrease in specific thrust and increase in specific fuel consumption rates as the flight Mach number increases. However, the turbine-burner engines show a slower decrease in specific thrust than the base engines. Furthermore, the turbine-burner engines are capable of operating at higher flight Mach numbers than the base engines, extending the operation envelop.

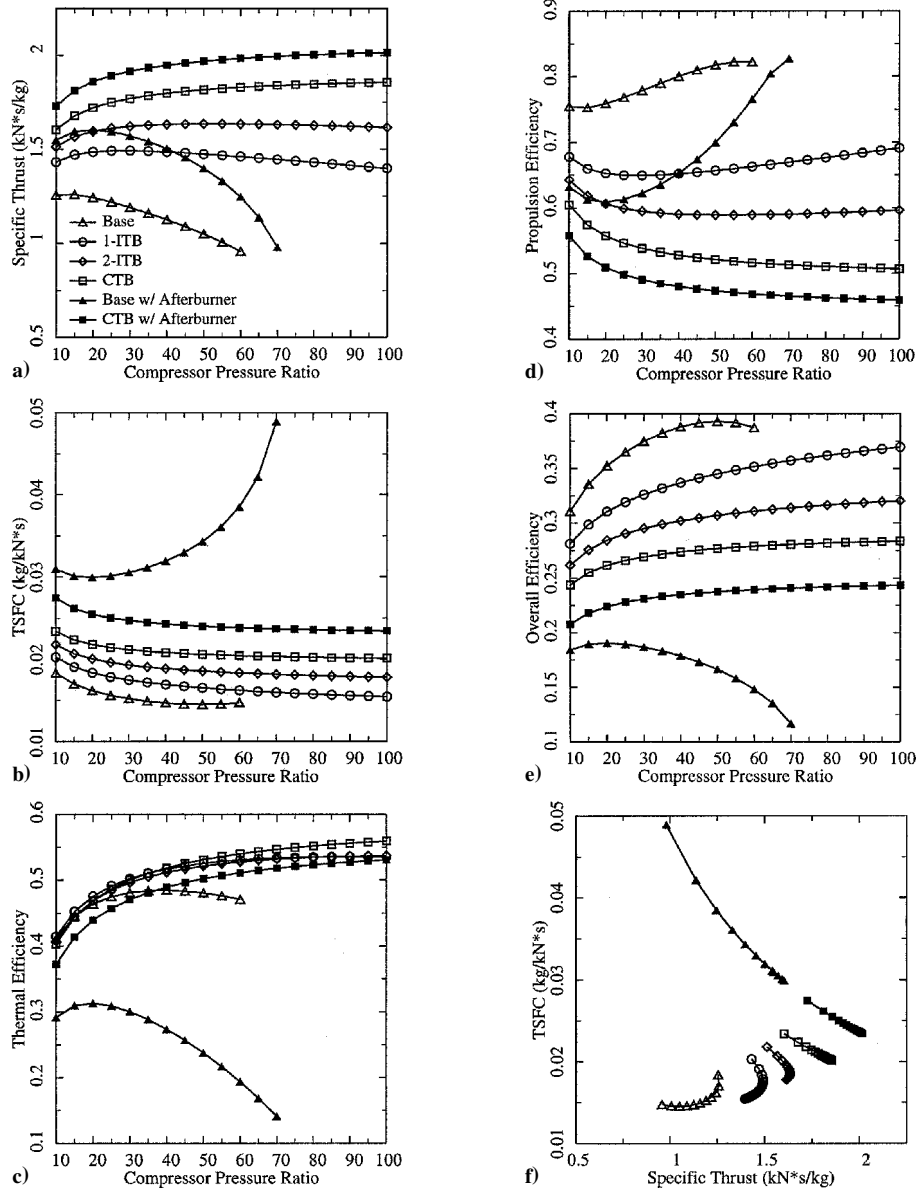

Fig. 7 Performances of turbofan engines vs compressor pressure ratio at $M_\infty = 0.87$, $T_{04} = 1500$ K, $T_{06} = 1900$ K, $\beta = 8$, and $\pi_f = 1.65$.

Figure 11 shows the performance comparisons for the various turbofan engines of bypass ratio of 8 with flight Mach number in the range of 0 to 2.5. The behavior of the turbofan engines at different flight Mach numbers are qualitatively similar to those of the turbojets. However, the conventional base engine does not operate well at all for supersonic flight whereas the turbine-burner engine continues to operate well in supersonic flight range. However, we note that this is on the assumption that the aerodynamic performance of the fan does not deteriorate at supersonic speed. This may be difficult with current fan technology for high bypass ratios.

VII. Variation of Turbine Inlet Temperature

One can argue that the advantages of the turbine burner, CTB or ITB, may be eroded when the turbine inlet temperature can be raised by improved cooling and/or high-temperature materials. Figures 12 and 13 show the performance of the turbojet engines flying at $M_\infty = 2$ and the turbofan engines flying at $M_\infty = 0.87$, respectively, for different turbine inlet temperatures from 1400 to 1800 K. Except for the fact that the base engines do not perform well at low turbine inlet temperatures, the curves for the different engines are almost parallel with exactly the same relative standings throughout the inlet temperature range. This clearly indicates that

the turbine-burner engines benefit equally from higher turbine inlet temperatures as the base engines do. The general trends are that raising the turbine inlet temperature increases the specific thrust of the engines with a small increase in fuel consumption rate. Therefore, we should not view the development of the turbine-burner engine technology being inconsistent with the push to increase the turbine inlet temperature. An increase in turbine inlet temperature will equally improve the performances of both the base engine type and the turbine-burner engine type.

VIII. Variation of Turbine Power Ratios

For the 1-ITB and the 2-ITB engines an important design consideration is the distribution of turbine power among the segments of turbines separated by the interturbine burners. For instance, the 1-ITB design separates the complete turbine into two segments with the ITB in the middle. A natural location of the ITB would be between the conventional HP turbine and the LP turbine although it does not have to be. In addition to considerations governed by other design constraints, the choice of the power distribution of the HP and LP turbines becomes an important cycle parameter in the case of the 1-ITB engine because heat is now added in between the two turbines, which can significantly affect the thermal efficiency of the

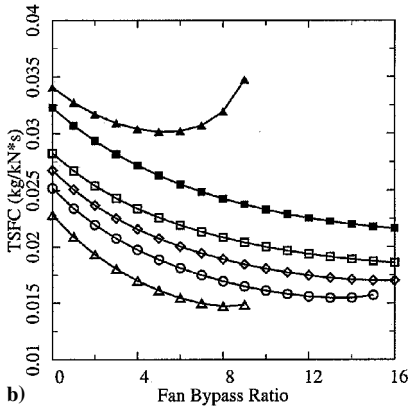
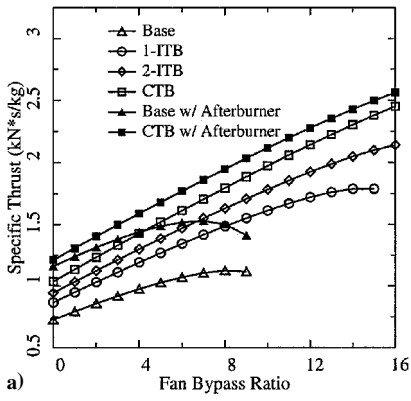

Fig. 8 Performances of turbofan engines vs fan bypass ratio at $M_\infty = 0.87$, $T_{04} = 1500$ K, $T_{06} = 1900$ K, $\pi_c = 40$, and $\pi_f = 1.65$.

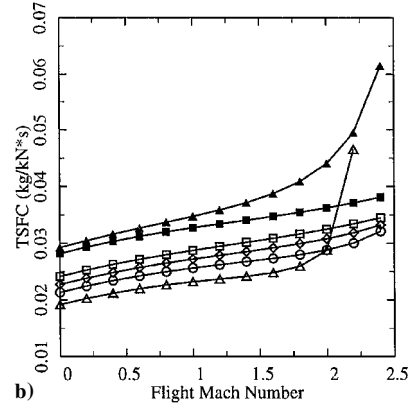
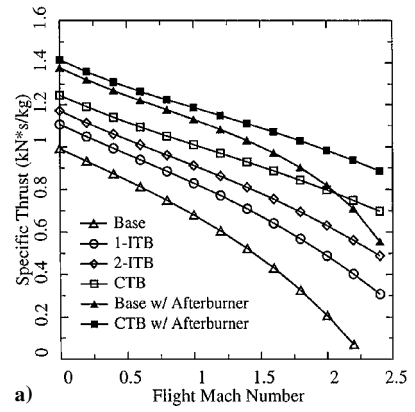

Fig. 10 Performances of turbojet engines vs flight Mach number. $T_{04} = 1500$ K, $T_{06} = 1900$ K, and $\pi_c = 40$.

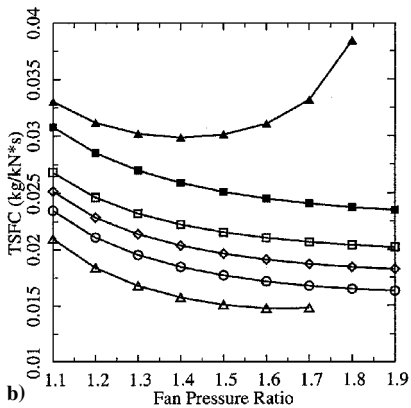
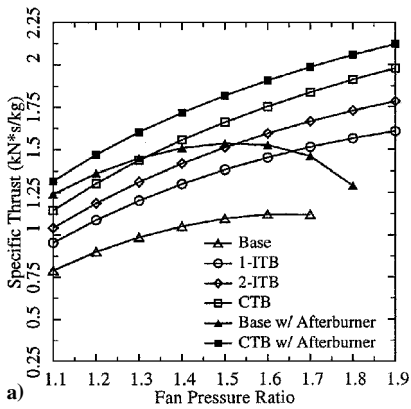

Fig. 9 Performances of turbofan engines vs fan pressure ratio at $M_\infty = 0.87$, $T_{04} = 1500$ K, $T_{06} = 1900$ K, $\pi_c = 40$, and $\beta = 8$.

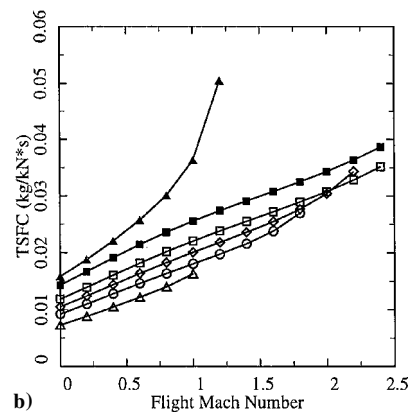
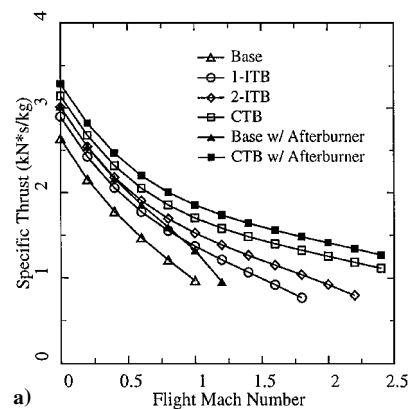

Fig. 11 Performances of turbofan engines vs flight Mach number. $T_{04} = 1500$ K, $T_{06} = 1900$ K, $\pi_c = 40$, $\beta = 8$, and $\pi_f = 1.65$.

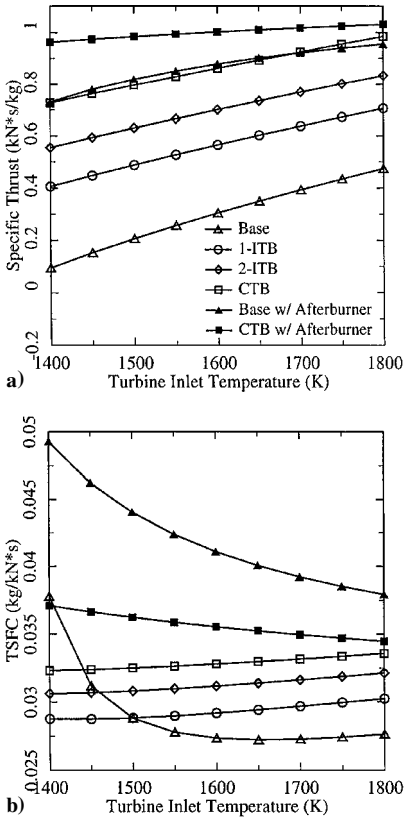

Fig. 12 Performances of turbojet engines vs turbine inlet temperature at $M_\infty = 2$, $T_{06} = 1900$ K, and $\pi_c = 40$.

engine. In a particular design of a multiple ITB engine, the power distribution among the segments of turbines that sandwich the ITBs should be optimized for a given mission. In this section we consider only the 1-ITB engine because it has only one parameter to vary, and yet it shows the essence of the physical significance of the power distribution.

Consider the 1-ITB turbojet configuration at a flight Mach number 2 with a compressor compression ratio of 30 and a maximum turbine inlet temperature $T_{04} = 1500$ K. For convenience, we will call the turbine section before the ITB to be the HP turbine and the section behind the ITB the LP turbine although they may not necessarily correspond to the conventional definition of the HP and LP turbines as just mentioned. We define a power ratio of the HP turbine ξ as the ratio of the power of the HP turbine to the combined total power of the HP and LP turbines. Figure 14 shows the performance parameters as we vary ξ from 0 to 1 as compared to the conventional engine with and without an afterburner, the 2-ITB engine with a fixed 33 : 33 : 34 power ratio for its three segments of turbines, and the CTB engine. The performances of all of these engines except the 1-ITB engine are shown as straight lines in the figure because they are independent of ξ . For the 1-ITB engine, however, the performance parameters vary with ξ .

When ξ is small, it means that we have a low-power HP (the ITB is very close to the front of the turbine). The temperature drop after the HP is small, and thus the amount of heat we can add in the ITB is limited for a given maximum inlet temperature of the LP turbine. We therefore expect the performance of the 1-ITB engine to approach that of the conventional base engine when ξ is small. In the limit when $\xi = 0$, the 1-ITB engine becomes the conventional base engine because the amount of heat added to the ITB is zero. Figure 14 shows that the performance of the 1-ITB engine falls right on top of the conventional base engine for $\xi = 0$. As ξ increases, both the ST and the TSFC increases. However, the ST rises much faster than the TSFC as shown in Figs. 14a and 14b. In fact, the ST increases significantly with little increase in TSFC for small ξ . On the TSFC-ST map this is shown by almost a straight line moving to the right with only a small upward motion. This very desirable

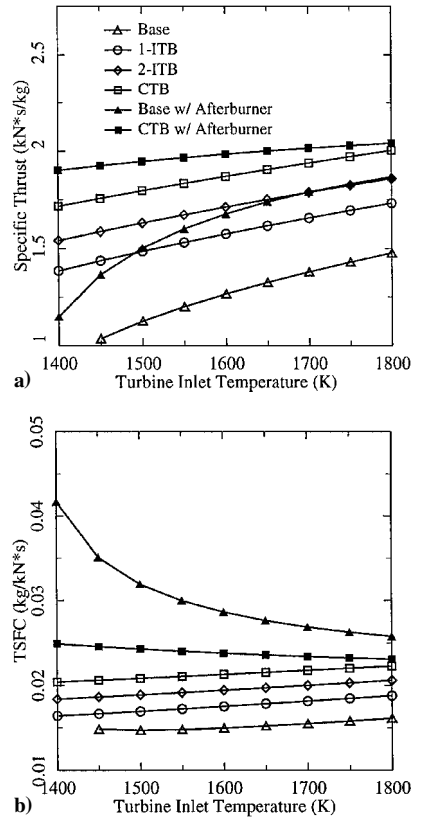

Fig. 13 Performances of turbofan engines vs turbine inlet temperature at $M_\infty = 0.87$, $T_{06} = 1900$ K, $\pi_c = 40$, $\beta = 8$, and $\pi_f = 1.65$.

change is a result of the significant increase of the thermal efficiency of the 1-ITB engine as ξ increases from 0, shown in Fig. 14c. The maximum thermal efficiency is reached at about $\xi = 0.40$. Beyond that η_t begins to decrease. This is because at higher ξ the pressure drop across the HP turbine is high. The ITB will then operate at lower pressure, reducing the thermal efficiency of the cycle. In fact, when ξ goes to 1 the 1-ITB engine becomes a conventional turbojet with an afterburner of temperature $T_{06} = T_{04}$. This is clearly shown in Fig. 14 where the performance of the conventional turbojet with the afterburner is calculated with a $T_{06} = T_{04} = 1500$ K.

The preceding discussions show the physical significance of the power distribution of the turbine segments in a multiple ITB design. It should be optimized for each particular mission and choice of configuration. In the rest of the discussions, however, we will restrict to a $\xi = 0.4$ for the 1-ITB engine, which incidentally is close to the optimum for the preceding turbojet example. For the 2-ITB engine we will still use the 33 : 33 : 34 distribution.

IX. Optimal Design Comparisons of the Base Engines and Turbine-Burner Engine

We have compared performances of the various engine configurations with identical design parameters and flight conditions. The studies indicate that the turbine-burner engine offers advantages over their base engine counterparts for all of the design parameters just considered. It is clear, however, from the preceding studies that the base engines and the turbine-burner engines do not operate optimally for the same set of design parameters and flight conditions. The turbine-burner engines obviously favor higher compressor pressure ratios, higher bypass flow rate, and higher fan pressure ratios. Therefore, it is appropriate that we design our turbine-burner engines to operate at their favorable conditions and compare their performances to those of the base engines also operating with their optimal design parameter ranges. Short of doing any systematic optimization, we compare the two kinds of engines operating at their own favorable conditions deduced from the single parameter studies obtained from preceding sections.

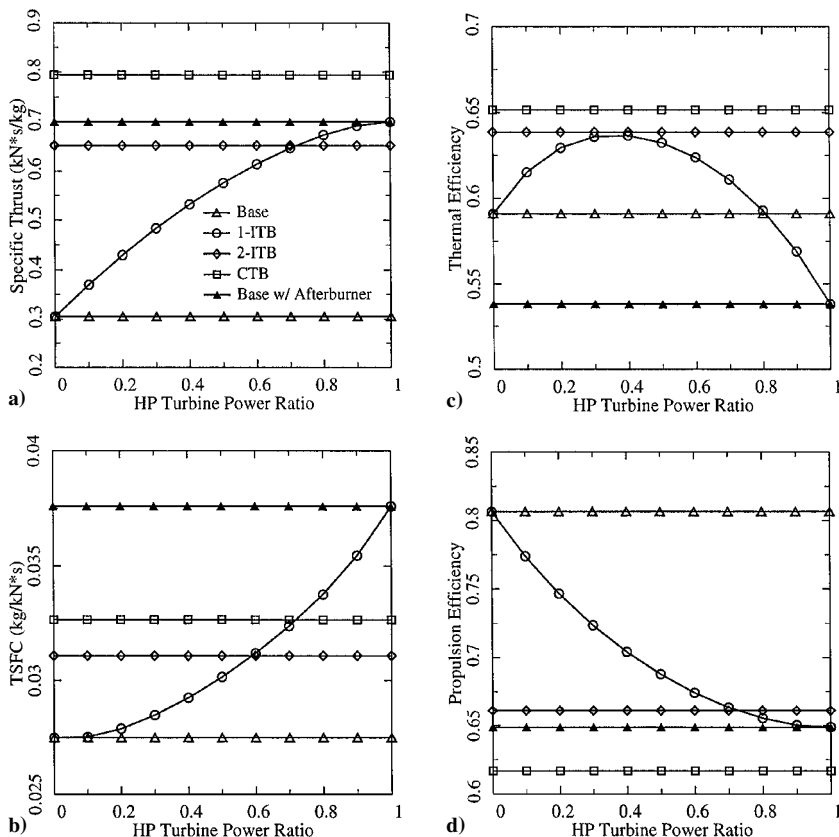

Fig. 14 Variation of turbine power ratio for the 1-ITB turbojet engine at $M_\infty = 2.0$, $T_{06} = T_{04} = 1500$ K, $\pi_c = 30$; the 2-ITB engine is with fixed 33 : 33 : 34 power ratio.

First consider the turbojet engines. For the conventional engines we choose the following design parameters: compressor pressure ratio $\pi_c = 30$, turbine inlet temperature $T_{04} = 1500$ K, and afterburner temperature $T_{06} = 1900$ K. For the turbine-burner engines we choose $\pi_c = 60$. Other parameters are the same. The performances of these engines are then plotted in Fig. 15. These figures show that the turbine-burner engines are clearly superior to their base engine counterparts. The percentage gain in specific thrust of the 1-ITB engine over the base engine increases from about 10 to about 30% as the flight Mach number increases from 0 to 2. The specific fuel consumption rate is almost identical for subsonic flight and only begins to increase slightly over that for the base engine when the flight Mach number exceeds 1. At Mach number 2 the 1-ITB engine is capable of producing 30% more thrust while incurring less than 5% increase in specific fuel consumption rate; the CTB engine is capable of producing 166% more thrust with only 18% increase in specific fuel consumption rate compared to the base engine. The 2-ITB engine falls in between the 1-ITB and the CTB engines in performance.

Next, consider the turbofan engines. We choose $\pi_c = 30$, $\pi_f = 1.65$, and $\beta = 8$ for the conventional engines, and $\pi_c = 60$, $\pi_f = 1.75$, and $\beta = 12$ for the turbine-burner engines. Figure 16 show the performance of these engines vs flight Mach number. These figures again show that the turbine-burner engines are far superior to their base engine counterparts. Now, the 1-ITB engine provides about 50% increase in specific thrust than the base engine, even more than the thrust of the base engine with the afterburner, whereas its specific fuel consumption rate is lower than or equal to that of the base engine without the afterburner for the entire subsonic flight range. At Mach number 1 the 2-ITB engine produces 80% more specific thrust while incurring only about 10% increase in specific fuel consumption rate; the CTB engine is capable of producing 120% more thrust with about 15% increase in specific fuel consumption rate compared to the base engine. More significantly, the 2-ITB and the CTB engines are capable of operating over the entire 0 to 2 flight

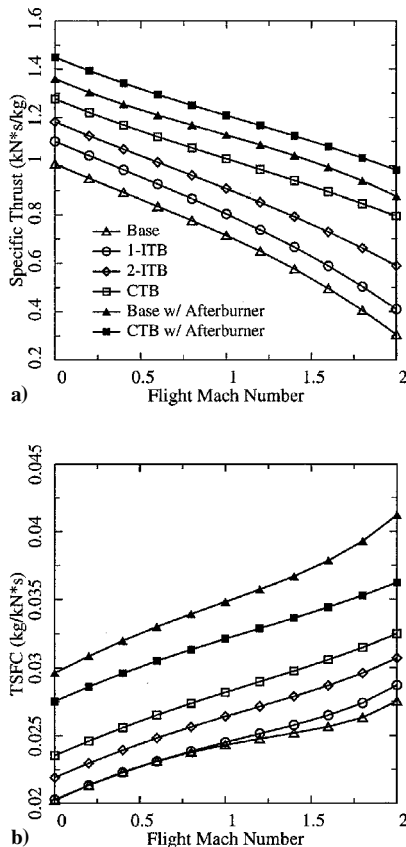

Fig. 15 Performance comparisons for turbojet engines vs flight Mach number. $T_{04} = 1500$ K, and $T_{06} = 1900$ K; $\pi_c = 30$ for the conventional engines; $\pi_c = 60$ for the turbine-burner engines.

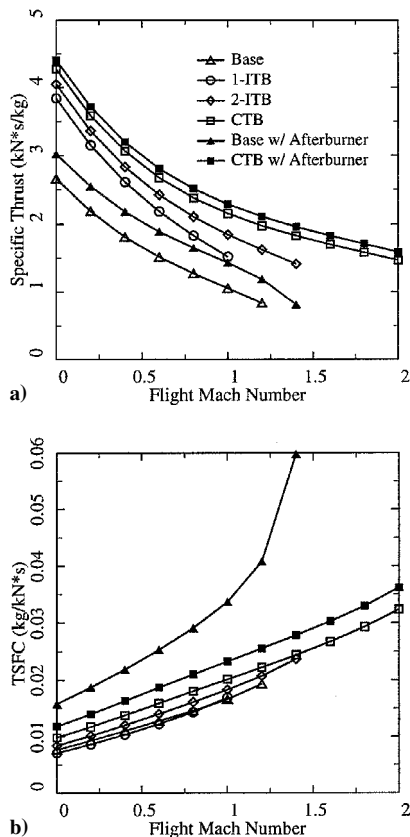

Fig. 16 Performance comparisons for turbofan engines vs flight Mach number. $T_{04} = 1500$ K, and $T_{06} = 1900$ K; $\pi_c = 30$, $\pi_f = 1.65$, and $\beta = 8$ for the conventional engines; $\pi_c = 60$, $\pi_f = 1.75$, and $\beta = 12$ for the turbine-burner engines.

Mach range. The conventional base engines cannot operate beyond Mach 1.25.

With this type of improvement in performance, it is certainly worthwhile to face the added challenge of designing a CTB or ITB with efficient high-bypass and high-speed fans and high-pressure compressors to complement the CTB and ITB designs.

X. Conclusions

A thermal analysis has shown the advantages of CTB and discrete ITB engines for both the turbojet and turbofan configurations. Burning in the turbine passages reduces the tradeoff between ST and TSFC. It allows significant increases in ST with only small increases in TSFC. The fundamental benefit of a CTB or ITB engine is to be able to produce gases of high kinetic energy at high thermal efficiency, providing a very desirable gas generator as the basis of high-performance engines applicable to both military and commercial applications.

The parametric studies in this paper have shown the following:

1) The turbine-burner engines are capable of and favor operations at high compressor pressure ratios. Although conventional engines may have an optimal compressor pressure ratio between 30–40 for supersonic flight, beyond which they have diminished thrust and very high TSFC, the turbine-burner engines are capable of operating at pressure ratios higher than 60. Increased compressor ratios generally increase ST and decrease TSFC of the turbine-burner engines.

2) Because of the extended compressor pressure ratio range and also of the fact that the propulsion efficiency improves at high speed for jet propulsion, the performances of the turbine-burner engines are significantly superior at high flight speed to conventional engines.

3) The turbine-burner engines benefit more from efficient, large-bypass fans than the conventional engines. The bypass pressure ratio can be optimized for a given mission. To combine the benefit of both the high-speed flight and high bypass, efficient high-speed fans must be designed.

4) The turbine-burner engines benefit equally well as conventional engines do from high-turbine inlet temperatures that may result from development of new materials and/or turbine cooling technologies.

5) The power distribution among the segments of an ITB engine should be optimized for a given mission and a given configuration. There exists an optimal distribution for the best thermal efficiency.

When a turbine-burner engine is designed by taking advantage of the preceding features, potential performance increases are extremely high compared to the conventional engines. For the turbofan example studied in Sec. IX of this paper, the 1-ITB engine provides more than 50% increase in ST with equal or lower TSFC over the conventional base turbofan engine.

Acknowledgments

The authors thank the National Science Foundation for its support under Grant number CTS-9714930. The Grant manager is F. Fisher. Discussions with Mel Roquemore and his colleagues at the Air Force Aeronautical Laboratories have been very helpful.

References

- ¹Sirignano, W. A., Delplanque, J. P., and Liu, F., "Selected Challenges in Jet and Rocket Engine Combustion Research," AIAA Paper-97-2701, July 1997.
- ²Sirignano, W. A., and Liu, F., "Performance Increases for Gas Turbine Engines Through Combustion Inside the Turbine," *Journal of Propulsion and Power*, Vol. 15, No. 1, 1999, pp. 111–118.
- ³Sirignano, W. A., and Kim, I., "Diffusion Flame in a Two-Dimensional, Accelerating Mixing Layer," *Physics of Fluids*, Vol. 9, No. 9, 1997, pp. 2617–2630.
- ⁴Fang, X., Liu, F., and Sirignano, W. A., "Ignition and Flame Studies for an Accelerating Transonic Mixing Layer," AIAA Paper 2000-0437, Jan. 2000.
- ⁵Hill, P. G., and Peterson, C. R., *Mechanics and Thermodynamics of Propulsion*, 2nd ed., Addison Wesley Longman, Reading, MA, 1992, pp. 141–216.